

Reference: R 1003

Designation: swivel fitting, cylindrical head.

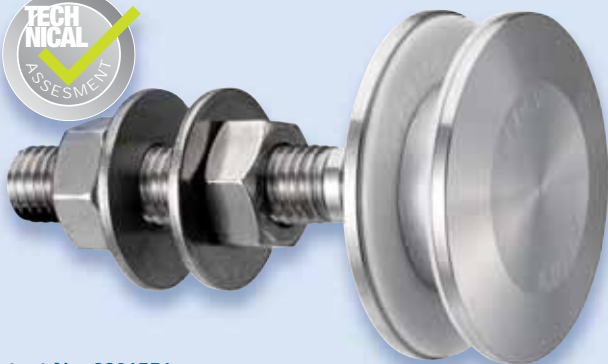

Typical applications:

Mounting		Alternate product
Vertical facade	Yes	
Roof/canopy	Yes	
Guard rail	Possible	V2003 - see SADEV Decor
*Blind access	No	R1008 - R1006 - R1038
Sloped glazing	Yes	

Patent No: 9806556  
 Technical assessment available online: [www.sadev.com](http://www.sadev.com)

\*Installation from the outside (no access to the structure).

Dimensions:

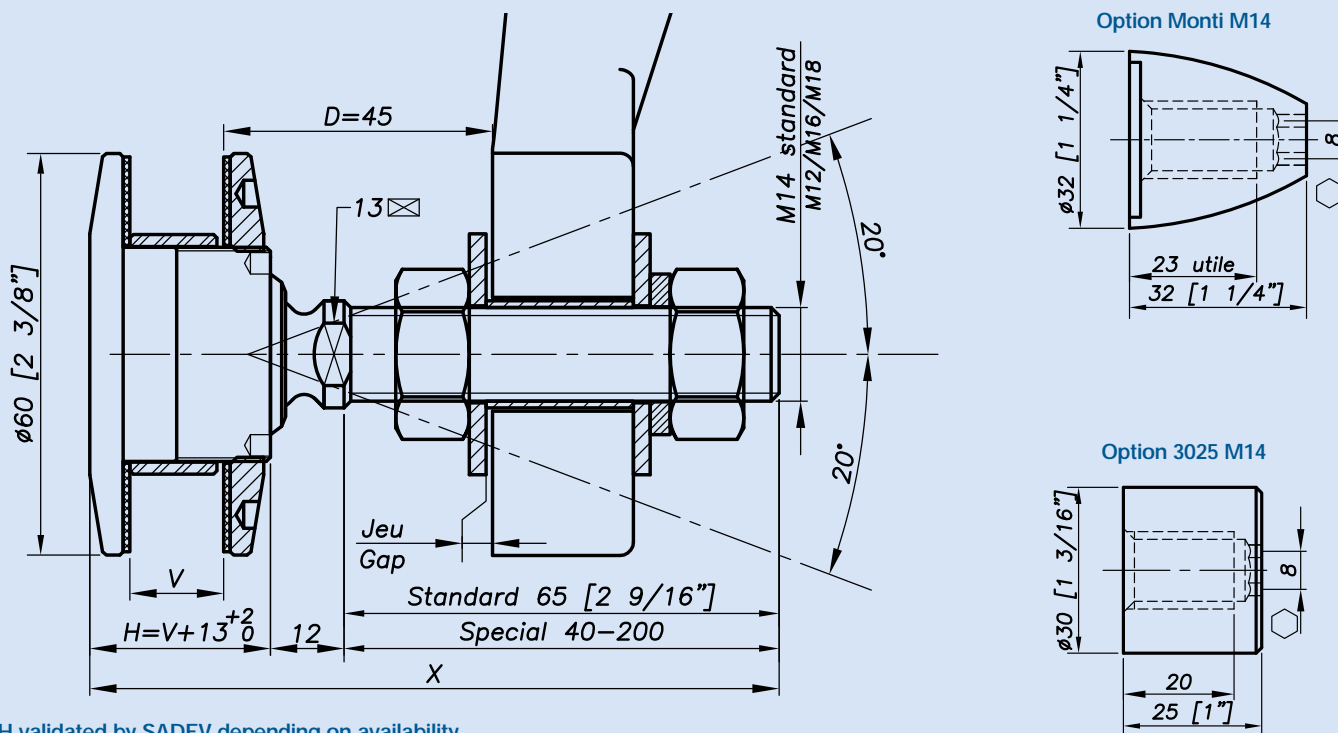

Glass drilling:

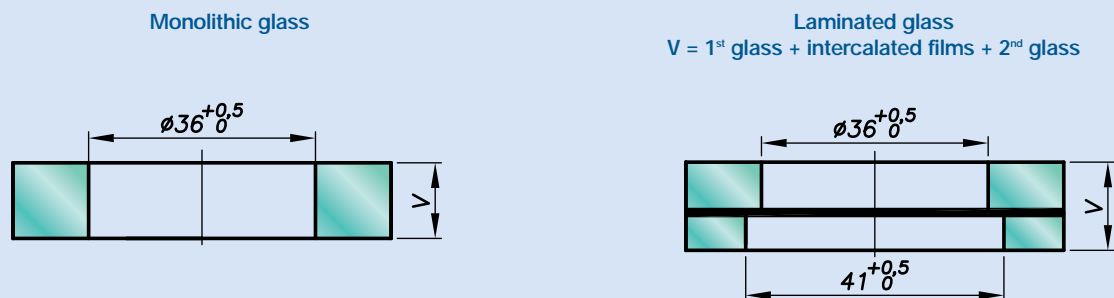

Available for glass thicknesses from 8 to 31.52 mm, for other thicknesses please consult us.

It is important to provide the following information with each request: the glass composition (ex.: 10 mm monolithic, 8.8.4 laminated, 8.8.2-12-10 insulating) / the length and diameter of the threaded axle if not standard dimensions (M14, 65 mm) / the reference of the spider to be used as support, or the thickness of an existing support for the delivery of the spacer.

Reference: R 1003

## Mechanical performances:

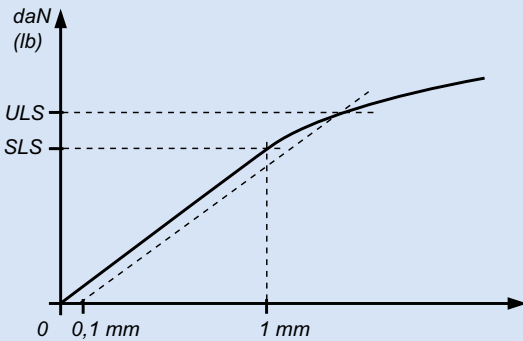

	Bending capacity			Pull out capacity
	D	SLS*	ULS*	ULS*
M14	45 mm	344 daN (773 lb)	577 daN (1297 lb)	2000 daN (4496 lb)
	60 mm	153 daN (344 lb)	364 daN (818 lb)	
M16	45 mm	504 daN (1133 lb)	827 daN (1859 lb)	2000 daN (4496 lb)
	60 mm	253 daN (569 lb)	525 daN (1180 lb)	

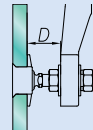

\*SLS – Serviceability Limit State: load at 1 mm deformation.  
 \*ULS – Ultimate Limit State: load at the elastic limit (Rp0.1).  
 Values are given without factor of safety.  
 Tests available online: [www.sadev.com](http://www.sadev.com)

## Components:

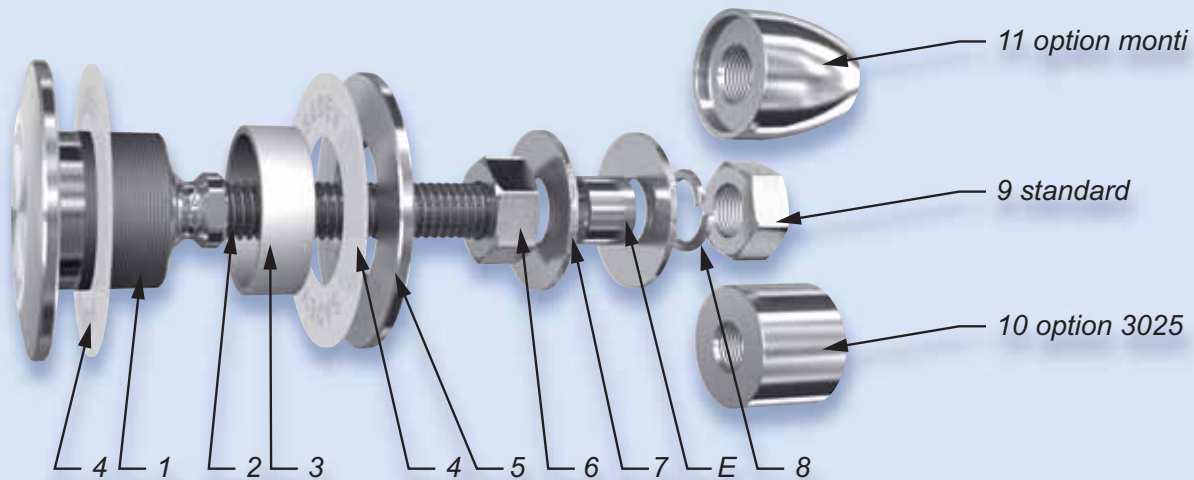

Rep	Qty	Designation	Material
1	1	Swivel Body	X2 Cr Ni Mo 17.12.2 per EN 10088-3
2	1	Threaded Axle	X4 Cr Ni Mo 16.5.1 per EN 10088-3
3	1	Glass Hole Grommet	AW-1050A per EN 573-3 / Al 99.5%
4	2	Contact Washer	White polyacetal / white polyethylene
5	1	Glass Nut Ø 60	X2 Cr Ni Mo 17.12.2 per EN 10088-3
6	1	Nut DIN 934	A4
7	2	Washer	A4
8	1	Lock Washer DIN127	A4
9	1	Nut DIN 934	A4
10	1	3025 Cap Nut - Option	X2 Cr Ni Mo 17.12.2 per EN 10088-3
11	1	Monti Cap Nut - Option	X2 Cr Ni Mo 17.12.2 per EN 10088-3

## Suggested mounting instruction:

Insert parts No. 1/2, 4, and 3 into the glass hole.

Mount the second contact washer No. 4 and nut No. 5 and tighten to 20 Nm (15 ft-lb) for monolithic glass and 10 Nm (7.5 ft-lb) for laminated glass using SADEV tools ref. 097581160 and ref. CLE-DYN-072031.

Thread on nut No. 6 and apply washer No. 7.

Insert the threaded axle into the support with spacer E (available on request), see technical page. Adjust the depth.

Mount the second washer No. 7, lock washer No. 8, and nut No. 9. Tighten to 60 Nm (45 ft-lb) using a 22 mm wrench.

SADEV recommends using thread locking compound whenever possible.